

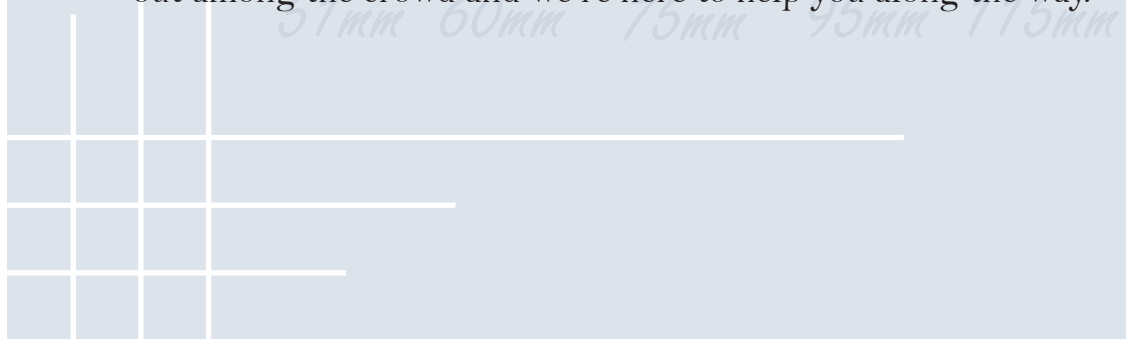

Wilpack Packaging is a division of A-American Companies, started in 1986 by Mark Keller and his Father, Vern. A-American Companies is founded on the same basic principles our Country was founded on: 'good old fashioned' faith, morals, values and ethics. Our company is family owned and operated, with quality products and innovative solutions designed and manufactured by our hard working team of individuals. Wilpack Packaging is proud to provide innovative tamper evident sealing solutions to meet your needs as well as provide customer safety and satisfaction. We understand what it takes to stand out among the crowd and we're here to help you along the way.



Quick



*Foil Seals
Cups*

51mm 60mm 75mm 75mm 115mm

*Model 15
Manual
Cup Sealer*

Change Nests

CONTENTS

MODEL 15 MANUAL CUP SEALER

4

MODEL 25 SEMI-AUTOMATIC CUP SEALER

6

F20 TABLE TOP FILLER

8

TAMPER EVIDENT VACUUM TESTER

10

W101 & W201 ROTARY MACHINES

12

*Model 25
Semi-Automatic
Cup Sealer*

P10 ROBOTIC PACK-OFF

*F20 Table Top
Filler*

15

PACKAGING SUPPLIES

16

1665 ELMWOOD MAP

18



MODEL 15 MANUAL CUP SEALER

ROBUST.

RELIABLE.

The Model 15 Manual Cup Sealer is a simple, durable and easy sealing solution. The Model 15 is made with a minimal design and washable food grade materials.

Ideal for products being sold in stores; the tamper evident seal prevents contamination and extends shelf life! The tamper evident seal secures the chain of custody, making sure that any product is safely transferred from you to your customer.

INCLUDED

Model 15 Manual Cup Sealer
51mm Cup/ 51mm Seal Nest
75mm Cup/ 79mm Seal Nest
115mm Cup/ 118mm Seal Nest



ALSO AVAILABLE

60mm Cup/ 61mm Seal Nest
95mm Cup/ 96.2mm Seal Nest



TAMPER EVIDENT SEALING

Air tight seals make any tampering or breakage obvious! When safety is a priority, tamper evident seals provide ease of mind when packaging your product!

SPILL PROOF SEALING

What's the most common customer complaint for "to go" orders? Sauces spilling in the bag. Snap caps popping off. Not anymore! Spill Proof Seals are strong and durable, allowing easy transportation!

EASY USE

It only takes minutes to learn how to use the Model 15 Manual Cup Sealer! The simple design and easy to follow instructions make it user friendly!

FOOD GRADE MATERIALS

The Model 15 Manual Cup sealer is made from food grade materials: which means that you don't have to worry about cross contamination after washing!

NSF APPROVED

The Model 15 Manual Cup Sealer has been NSF approved since 2015! Trust the experts and invest in a Model 15 Manual Cup Sealer!

ADVANCED.

CONSISTENT.

The Model 25 Semi-Automatic Sealer is a superior tabletop sealer. Weak, overly strong, or inconsistent seals are not a problem to the Model 25! Boasting easier, safer use, consistent seals, adjustable temperatures and dwell times, the Model 25 stands head and shoulders over all tabletop sealing machines.

The Model 25 is the perfect tool to be “chain of custody” compliant! Especially as carry out orders have become a focus in the food industry.



INCLUDED

Model 25 Semi-Automatic Sealer
51mm Cup/ 51mm Seal Nest
75mm Cup/ 79mm Seal Nest
115mm Cup/ 118mm Seal Nest

ALSO AVAILABLE

60mm Cup/ 61mm Seal Nest
95mm Cup/ 96.2mm Seal Nest

FEATURES

All Electric: No compressed air required
Adjustable Dwell Time
Adjustable Temperature

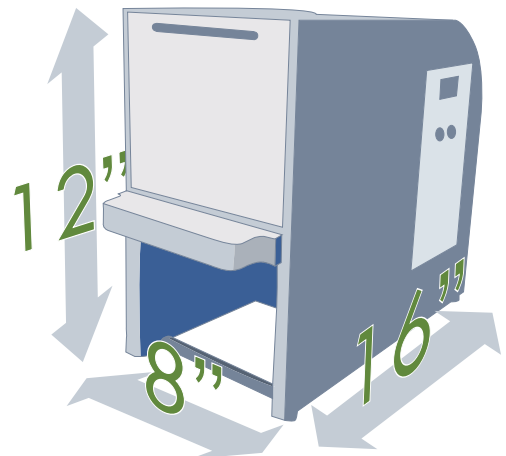



MODEL 25 SEMI-AUTOMATIC CUP SEALER



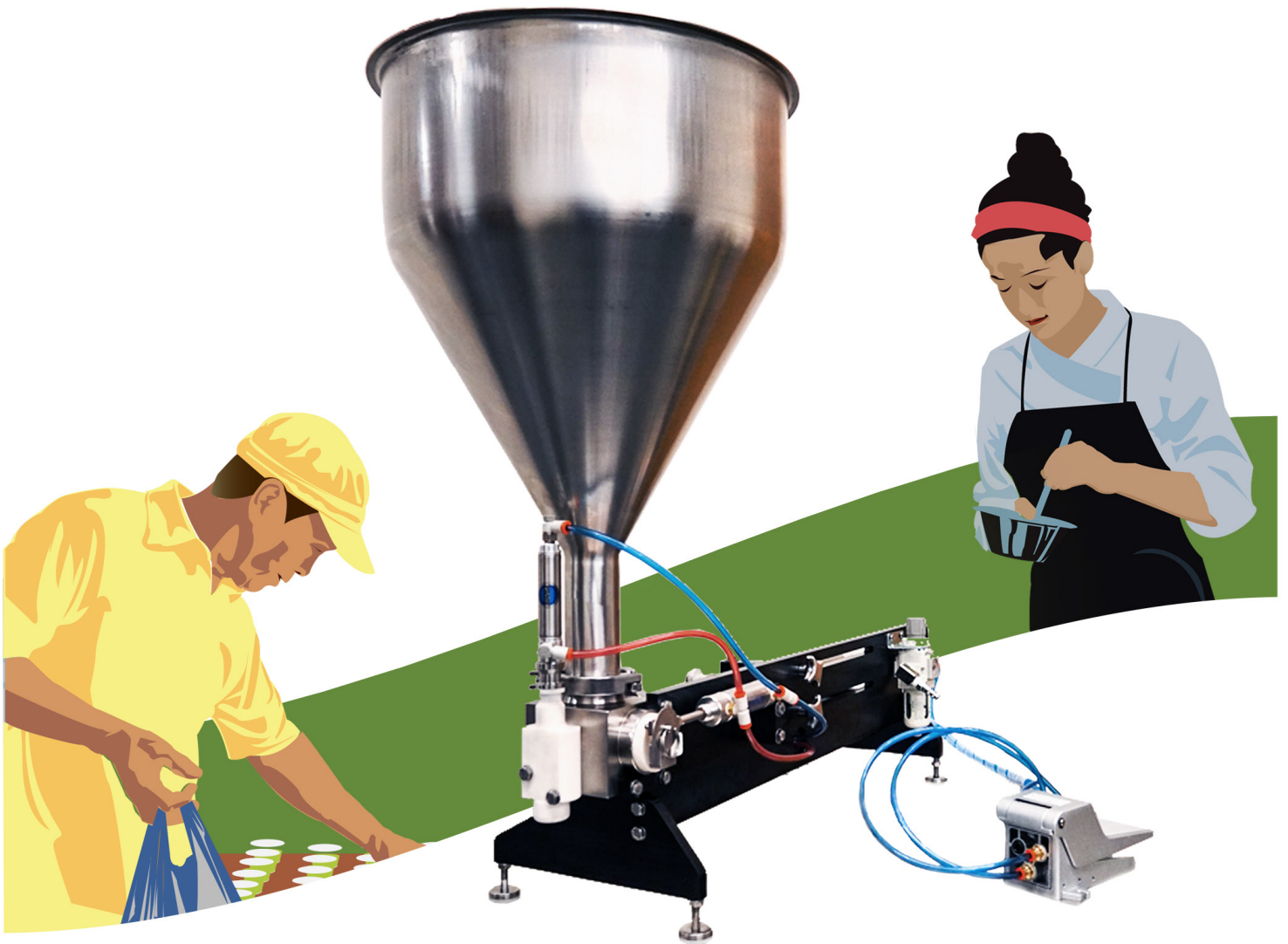

F20 TABLE TOP FILLER

PRECISION.

EXCELLENCE.

Paired with our Table Top Heat Sealing equipment, or simply on its own, the Table Top Filler allows quick and easy packaging in a variety of sizes and products. From salsas to your secret house sauce, the Table Top Sealer removes the hassle of pouring or squeezing your product into serving cups! The Table Top Sealer also utilizes “No Drip” technology which means more time packaging and less time mopping up the mess!



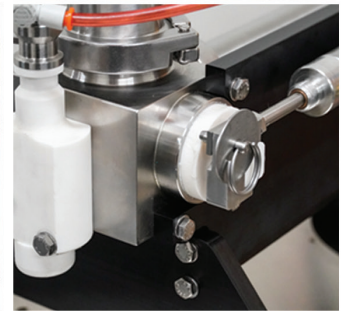
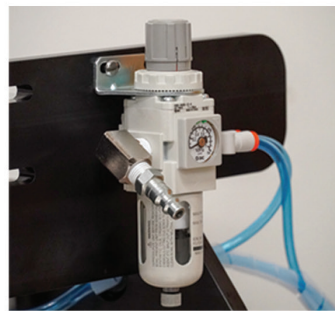
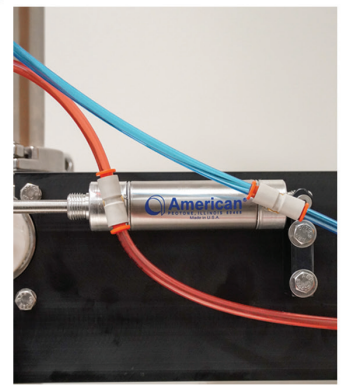
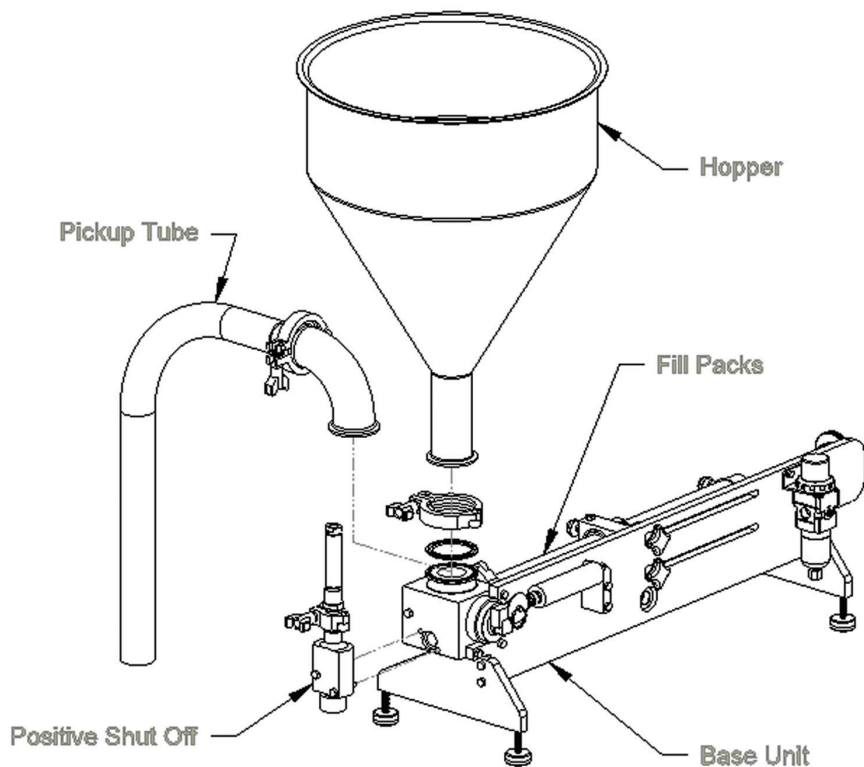

COMPONENTS

- With the Hopper, Filler measures 28 5/8" high, 9 3/4" wide, 28 3/4" long.
- Base components- Aluminum with food grade plating
- Food contact components- Food grade 316 stainless steel and food grade plastics.
- Air filter regulator
- Push to connect fittings
- Fill cycle triggered by foot pedal

FEATURES

- Hot or standard valve spool fill
- 5 Fill tube size options
- Supply - Hopper or pickup tube
- Easily breaks down for full washing
- Non-electric, only needs compressed air for operation

NO-DRIP POSITIVE SHUT OFF

- Works with up to 1/2" chunks in thinner products such as salsa, fruit cocktail, or chunky salad dressing
- Comes with 7 different sized Fill Rings for a perfect flow
- Cuts off "tail" in thicker products



TAMPER EVIDENT VACUUM TESTER

PROACTIVE.

ECONOMICAL.

The Tamper Evident Vacuum Tester is the best tool for testing the strength and integrity of your seals! Utilizing a quick and simple setup, the Tamper Evident Vacuum Chamber mimics an increased altitude pressure. Weak seals will burst and expose any issues prior to shipping your products! The Tamper Evident Vacuum Tester preserves quality and saves money by proactively preventing recalls, customer complaints, and wasted products! This makes the T.E. Vacuum Tester an integral part of Wilpack's sealable solutions line of products.



ENSURE

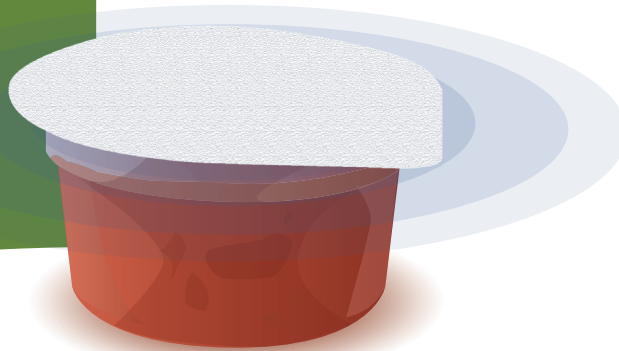

Quality

What is the price for ensuring quality? The Tamper Evident Vacuum Tester makes that choice easy! It's an inexpensive, effective, and easy to use solution to guarantee that your seals withstand the rigors of shipping, storing, shopping carts, and to go bags.

INCLUDED



High quality 110v Air Pump
Air Hose
Dessicator (Vacuum Chamber)

FEATURES

Complete testing kit: No other additional components required
Perfect for start up companies or a fully automated co-packer
Easy to use air pressure control
508 inches³ of chamber space
Easy access testing chamber



W101 & W201 ROTARY MACHINES

FEATURES

- Perimeter Guard with safety interlocks
- Touch screen HMI mounted on pack-off side
- Complete fault diagnostics
- Camco precision drive
- Controlled by Allen Bradley logic
- Safety sensors indicate no cup, no fill, & no foil

ADDITIONAL OPTIONAL COMPONENTS

- Hot fill adaptable
- Fill tube sizes allow a large range of cup volumes
- Feed options include hoppers (heated hopper available) and piping systems
- Level Control System
- Date coding for the top, side, or bottom
- Manual or robotic pack off systems
- Pneumatically controlled positive shut off valves and cup lifts

OPERATIONAL REQUIREMENTS

- Single operator (excluding pack-off)
- 220v single phase on a 20-amp circuit
- Clean & dry compressed air

BENEFITS

- Entirely automatic system controls mess & waste
- Very low maintenance
- Modular construction enables growth
- Compact footprint: Approximately 6' high & 4 sq. ft area
- W101 - up to 40 cups per minute
- W201 - up to 80 cups per minute

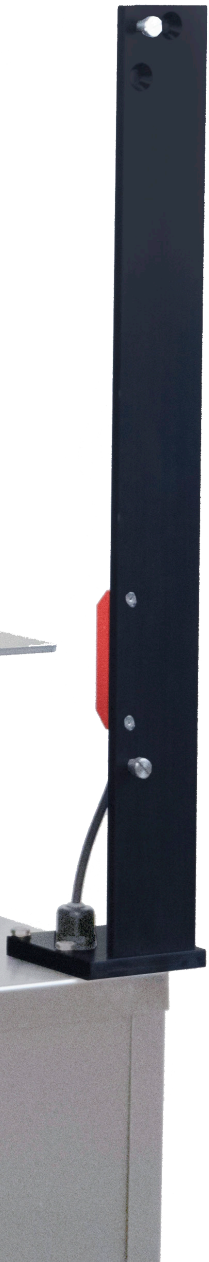

W101 & W201 ROTARY MACHINES

STATION OVERVIEW

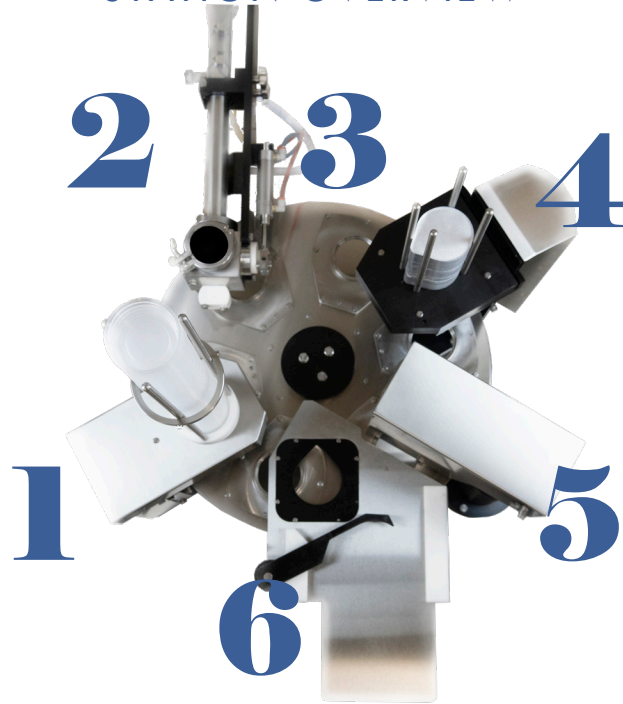

- | | |
|--------|-----------|
| 1: | Cup Drop |
| 2 - 3: | Filler |
| 4: | Seal Drop |
| 5: | Heat Seal |
| 6: | Unload |

TURN-KEY MODULAR SETUP

Rotary machines can be utilized in a modular setup, where multiple rotary machines supply an accumulating table using conveyors.

Benefits of the modular setup include:

- Multiple products packaged simultaneously.
- Up to 40 cups per minute on a single lane rotary and up to 80 cups a minute on a double lane rotary.
- Preventative maintenance on a single machine does not delay the whole production.

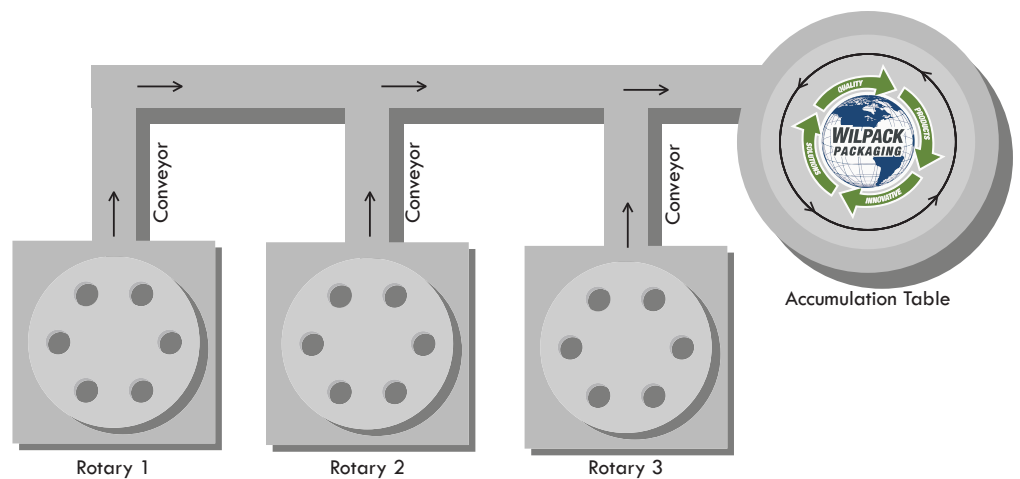

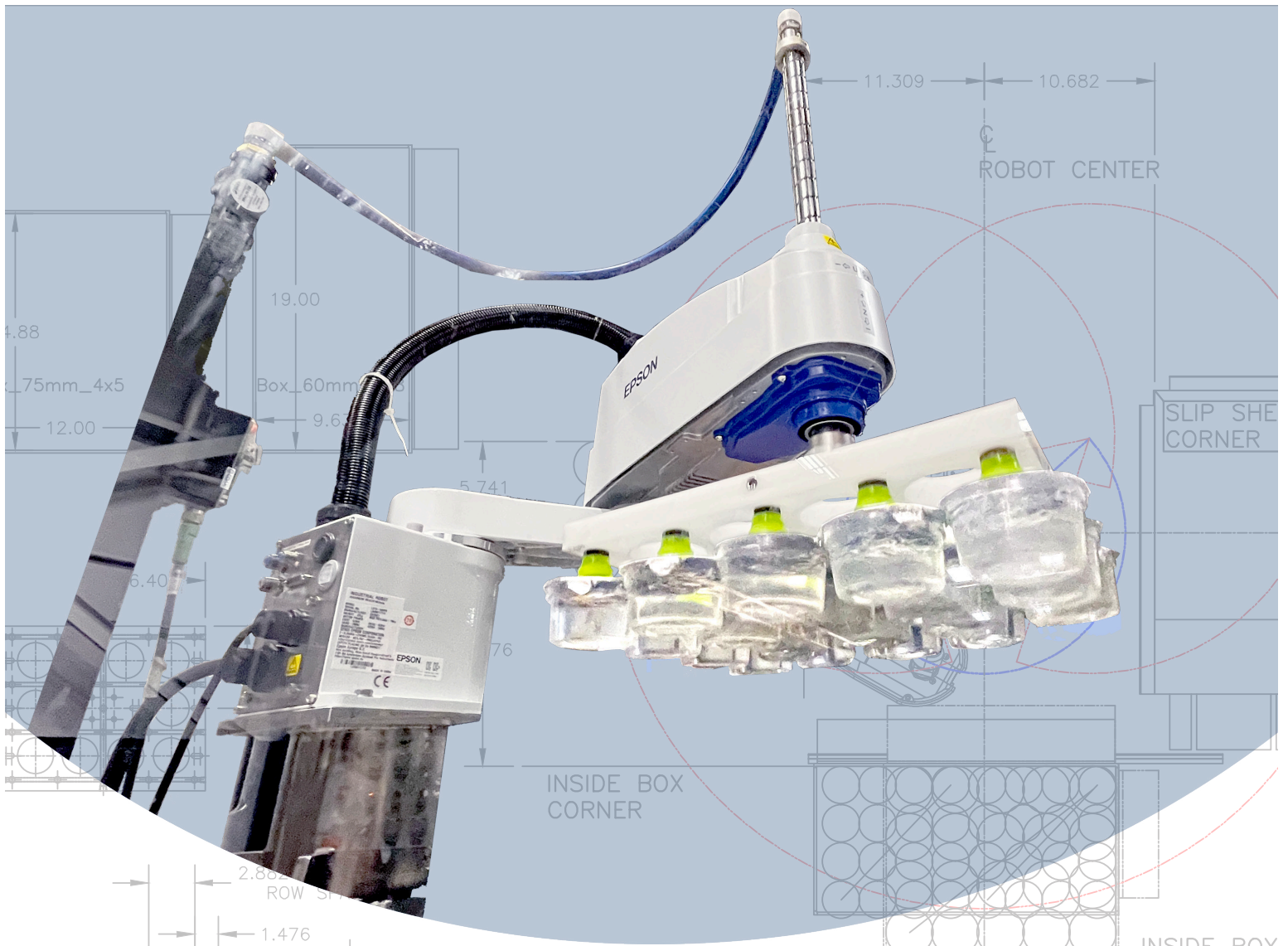

P10 ROBOTIC PACK-OFF

New from Wilpack Packaging! The P10 Robotic Pack-Off collects sealed cups from the Rotary Machines with a conveyor. Then the robot picks and places the cups into a box for transportation. Designed for high volume food packaging, it can pack up to 400 cups per minute.



75mm 4x5

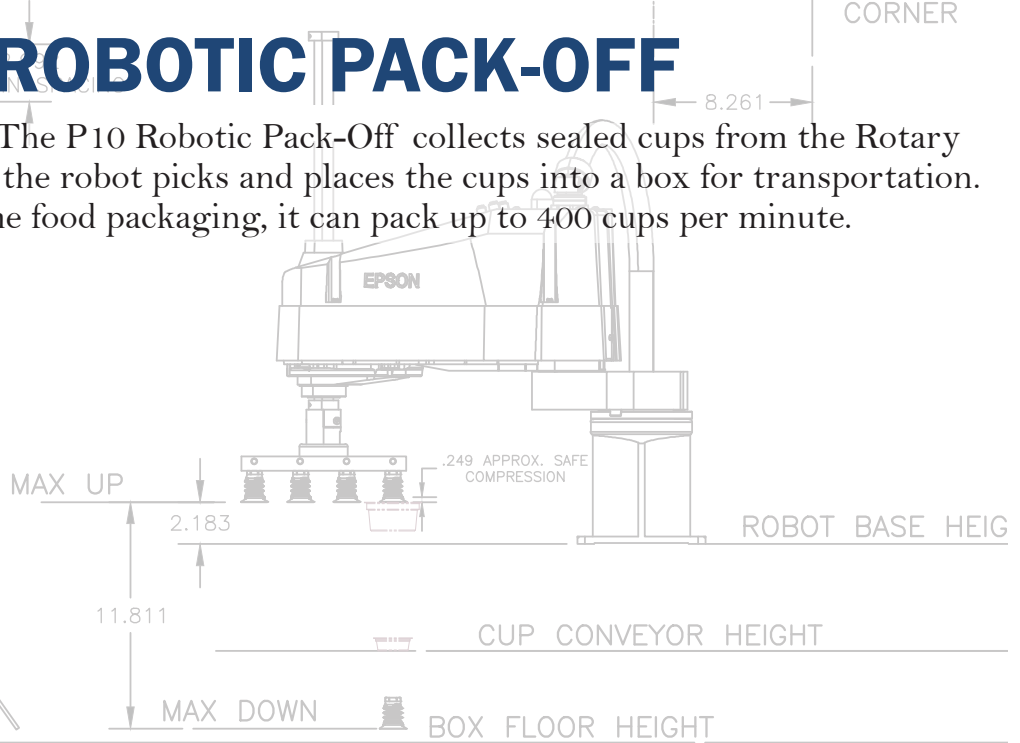
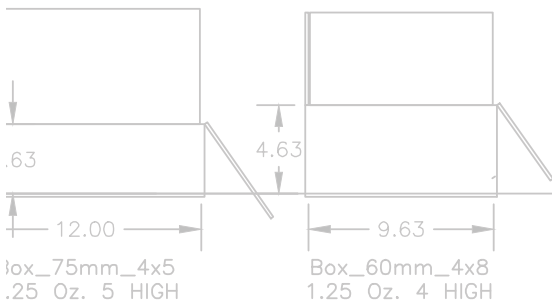

PACKAGING SUPPLIES

QUALITY IN.

QUALITY OUT.

The most reliable packaging for securing the chain of custody for your products: From kitchen to consumer.

From coast to coast, and even into Canada and Mexico, Wilpack Packaging is trusted with sourcing businesses of every size with their packaging needs. High volumes aren't required to begin purchasing!

All packaging sourced by Wilpack is guaranteed to work with Wilpack equipment which makes Wilpack a one-stop-shop for all packaging requirements!

Popular products include single serve portion cups, deli containers, foil seals, overcaps, you name it! As the restaurant takeout and delivery industries increase, popularity for *Tamper Evident* portion cups has also increased. It's a great way for suppliers to know as a matter-of-fact that their products are not ruined or messed with on the way to the shelf.

SPECIALTY CUPS

Specialty cups are also available in select sizes including freezer grade cups and medical grade cups!

CUSTOM PRINTING

Your custom logo/ product information can be printed onto the foil seals or on the side of the cups!

QUANTITY DISCOUNTS

Give our friendly sales team a call to get a quote for your packaging needs!



Wilpack Packaging Stock Cup Sizes

51 mm Cups		60 mm Cups		75 mm Cups		115 mm Cups		115 mm Cups Heavywall	
Clear	White	Clear	White	Clear	White	Clear	White	Clear	White
0.37 oz	✗		1 oz		1.25 oz		6 oz		8 oz
0.5 oz	✗		1.25 oz		1.5 oz		8 oz		
0.75 oz			1.5 oz		2 oz		12 oz		16 oz
1 oz	✗		2 oz		2.75 oz		16 oz	✗	
1.5 oz					3 oz		32 oz		32 oz
					4 oz				
					6 oz				

Stock Seal Sizes

51 mm Seals	61 mm Seals	75.5 mm Seals	79 mm Seals	115 mm Seals
3520 Standard Foil				
70975 Hard to Hold Foil		✗		
Poly Paper Poly Non-metallic Seal		✗		

Stock Lid Sizes

117 mm Snapcaps	117 mm Overcaps	117 mm Heavywall Overcaps
Clear		
White		

OUR HOME

We are located in the heart of the Midwest: Rockford, Illinois. Our state of the art facility accomodates all aspects of our business: from the office space for our customer service team, to the warehouse that is strategically organized for rapid order fulfillment.

Recently relocated from a 30,000 sq ft. building to the current 135,000 sq ft. building; the upgrade was a necessary step to meeting the needs of our growing customers and expanding customer base.

Come visit us next time you're in the area!

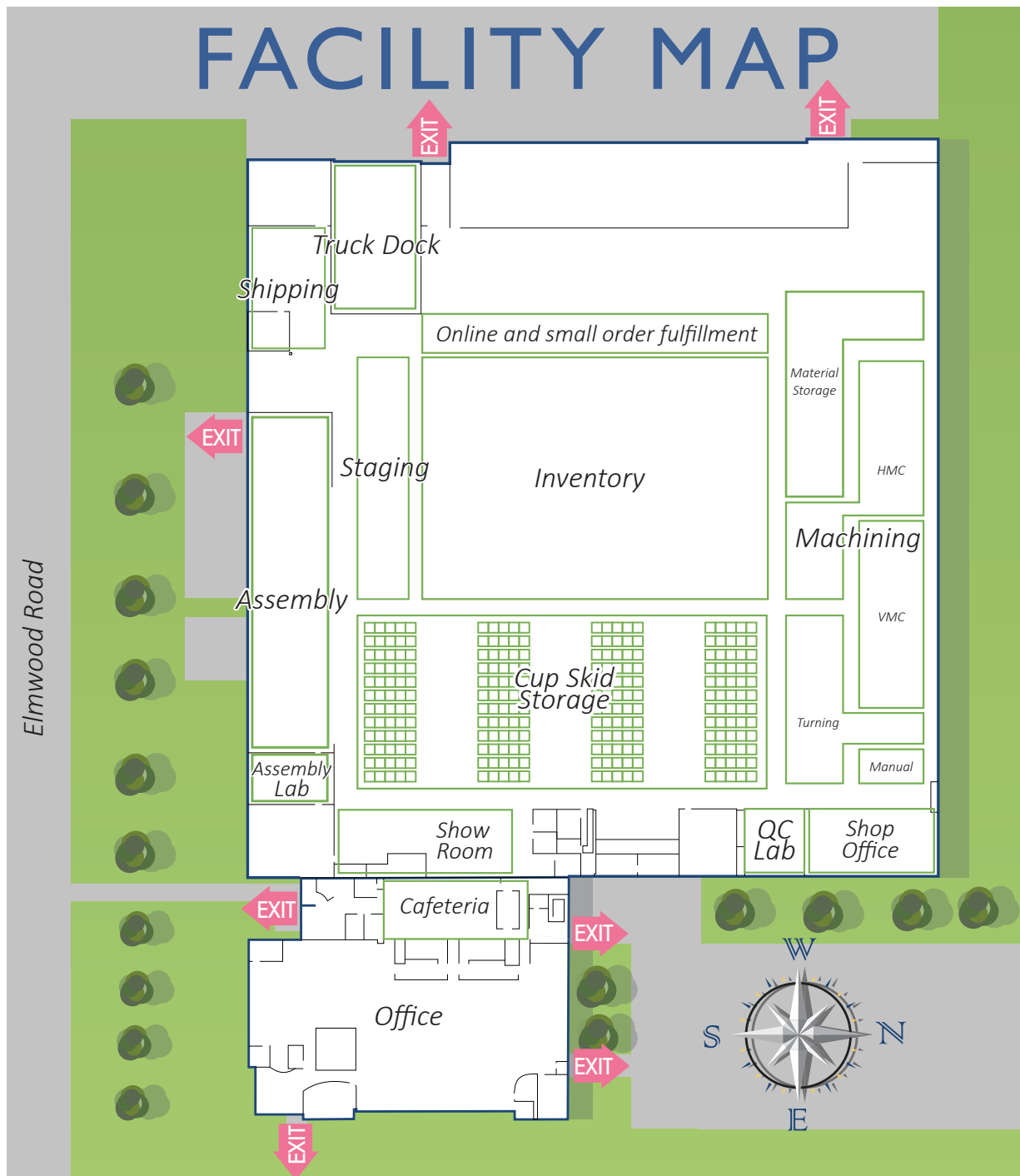

INTERESTING FACTS:

- Warehouse/Shop Area: 100,200 sq. ft
- Office Area: 35,400 sq. ft
- Facility built in 1969
- Total land: 14.6 Acres
- Eclipse aquired and moved in 1973
- A-American Machine & Assembly Company acquired and moved in 2021

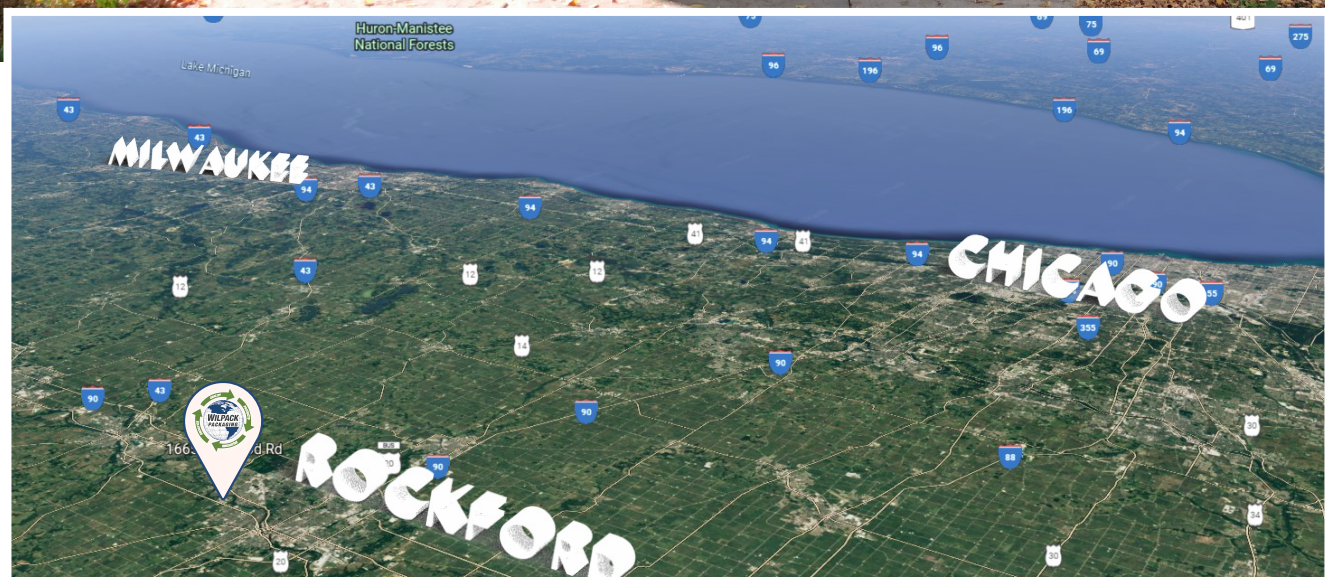

Your sealable solution company.

1665 ELMWOOD ROAD
ROCKFORD, IL 61101
815.490.9235

sales@wilpackpackaging.com
wilpackpackaging.com



Website



Instagram



Facebook



Youtube



Twitter